



Small Metal Enclosures
**Aluminum
Instrument Case**



Design Features

- Strong and stylish extruded aluminum body with plastic front and rear bezels
- Removable front and rear panels with protective film allow for easy scratch free machining
- Adjustable locking aluminum and plastic handle allows for multi-positional carrying and bench top use
- Extruded internal grooves for horizontal mounting of circuit board, chassis, or panel
- Four scuff resistant antiskid feet; front feet feature foldable bails
- Finish: Earth tone powder coated body with light brown plastic bezels and natural aluminum panels; handle is light gray plastic and anodized aluminum



EXTRUDED ALUMINUM INSTRUMENT CASE					
Catalog Number		External Dimensions			Wgt. Lbs.
		Height	Width	Depth	
IA-6160		2.72"	8.27"	12.93"	4
IA-6161		2.72"	10.16"	12.93"	5
IA-6162		4.92"	8.27"	12.93"	5
IA-6163		4.02"	10.16"	12.93"	6



4605 E. 355th Street • Willoughby, Ohio 44094
Phone: 440.946.3200 • Fax: 440.951.4015
email: saleseast@budind.com

PART NAME

ALUMINUM INSTRUMENT CASE

PART No.

IA-6161

REVISION DATE

-

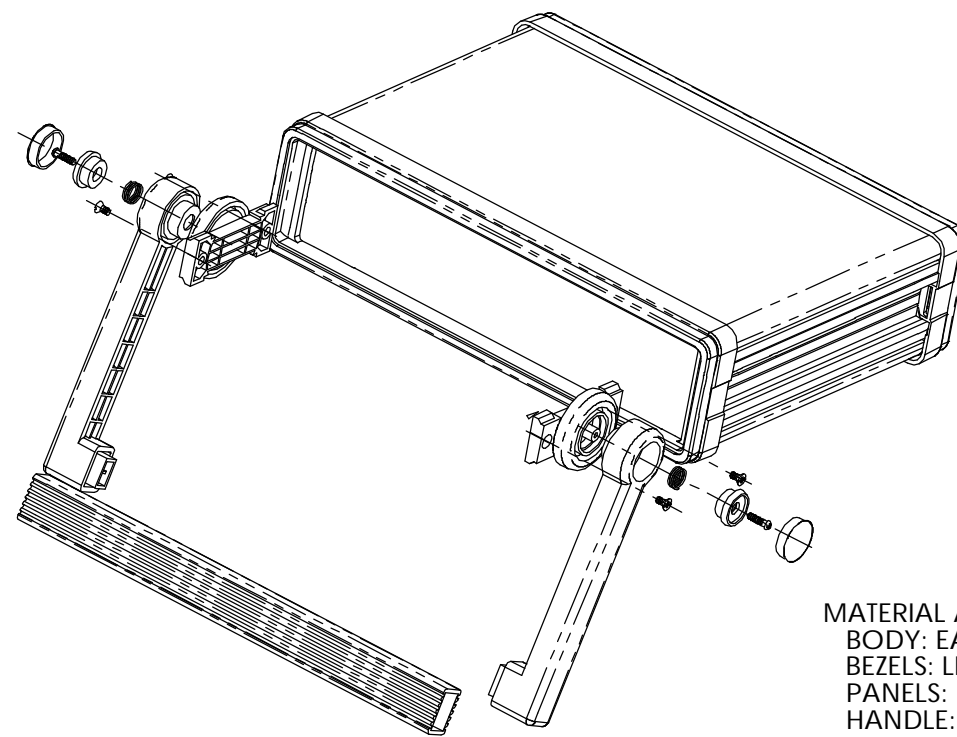
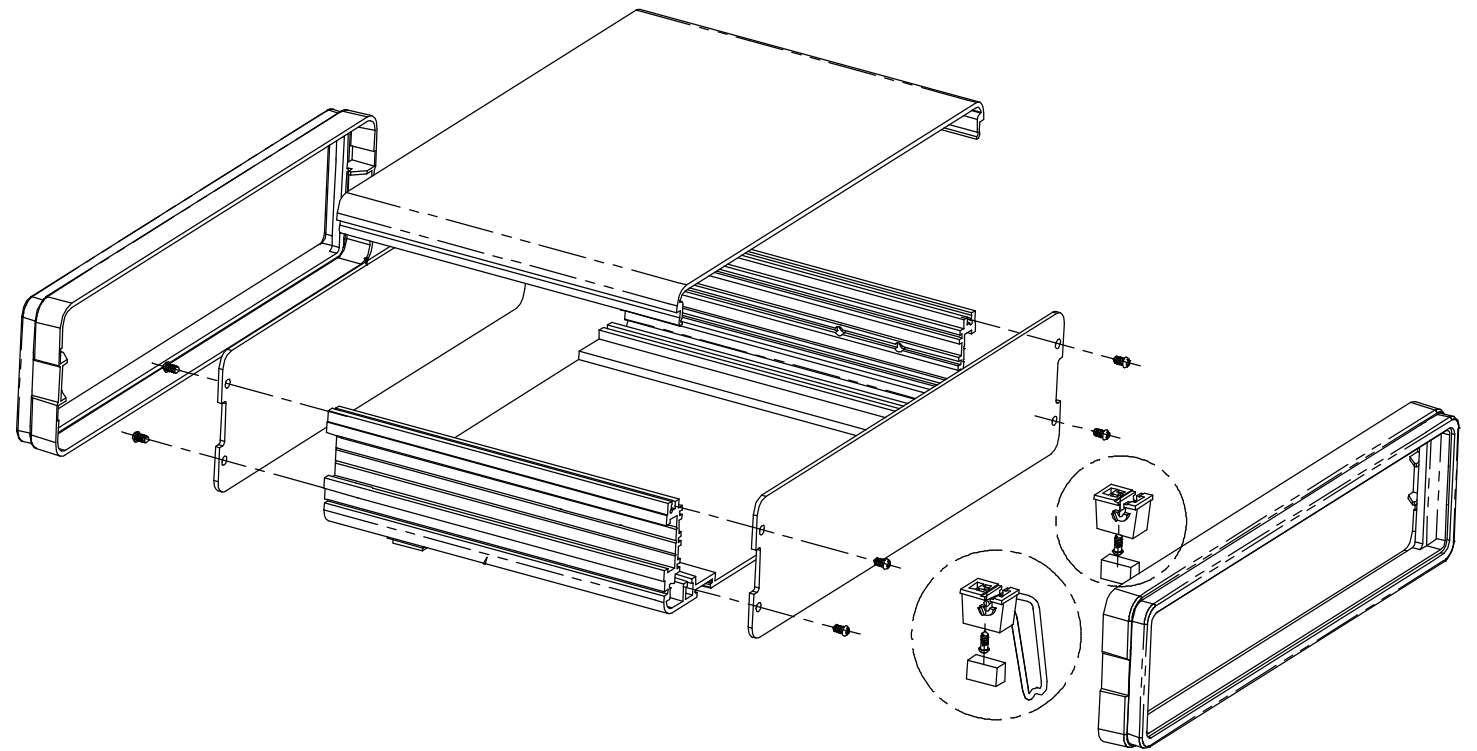
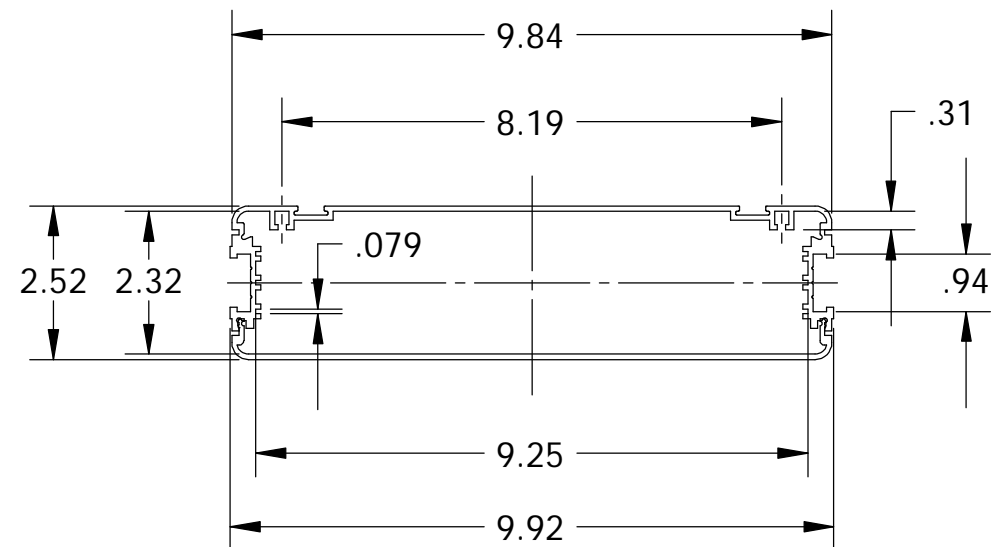
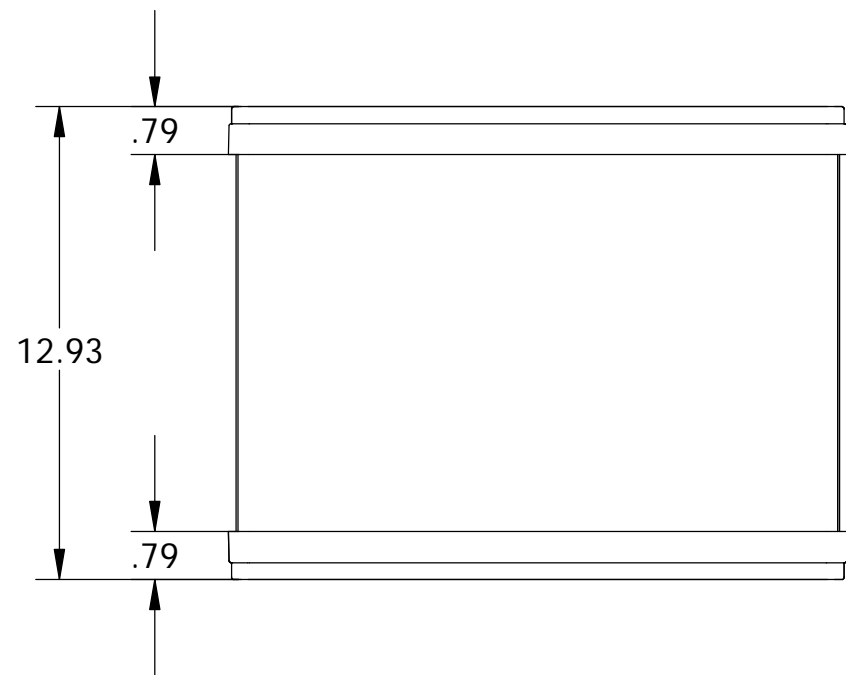
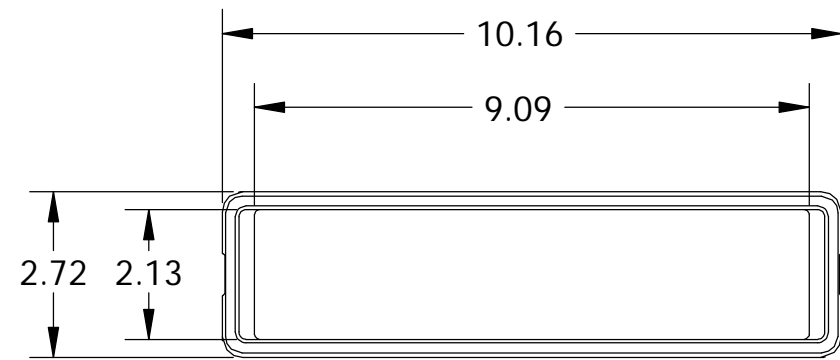

MATERIAL AND FINISH:
 BODY: EARTH TONE POWDER COATED ALUMINUM EXTRUSION
 BEZELS: LIGHT BROWN PLASTIC
 PANELS: NATURAL ALUMINUM
 HANDLE: LIGHT GRAY PLASTIC/ANODIZED ALUMINUM EXTRUSION

DIMENSIONS ARE IN INCHES